

V10000-275

MOUNTING KIT for COMPRESSION-LOW PROFILE load cells

LAUMAS®

Series load cells: CBL - CBX

Application range from 250 to 15000 kg



V10000



V10275

MAX STATIC LOAD kg	FOR LOAD CELLS	NET WEIGHT OF MOUNTING KIT (kg)	CODE
15000	CBL (250 ÷ 12500 kg) - CBX (15000 kg)	5.7	V10000
15000	CBL (250 ÷ 12500 kg) - CBX (15000 kg)	6.9	V10275

Load cell not included.

DESCRIPTION

- AISI 304 stainless steel upper and lower plates.
- AISI 304 stainless steel laminas against lateral forces.
- Anti-tilt system consists of two threaded bars with self-locking nut.

HORIZONTAL CONSTRAINERS ORIENTATION IN STRUCTURE WITH 3-POINTS SUPPORT

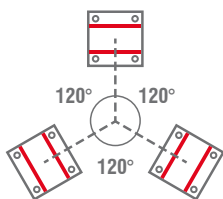

HORIZONTAL CONSTRAINERS ORIENTATION IN STRUCTURE WITH 4-POINTS SUPPORT

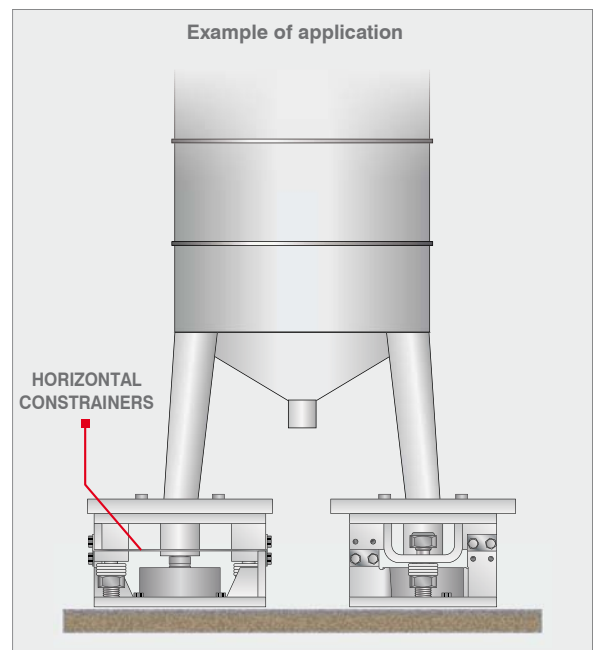
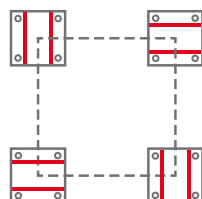

Rev. 0.0

V10000-275

MOUNTING KIT for COMPRESSION-LOW PROFILE load cells

LAUMAS®

DIMENSIONS AND TECHNICAL SPECIFICATIONS

Upper and lower plates **2** must rest completely on not deformable surfaces. To ensure the stability of the structure, the system designer must predict any further precaution against side shifts and anti-tilt in function of: knocks and vibrations, wind effect, seismic conditions and hardness of support structure.

- Install the weighed system using only the mounting kit without the load cell **1** and inserting in its place a piece of pipe (1-2 mm higher than the load cell).
- To finish the installation (weldings, etc.), remove the piece of pipe and then removing the bolts to fix the the load cell **7** insert the load cell **1** in mounting kit.
- Connect lower and upper plates **2** to the earthing system then loosen nuts **5**; erify that the threaded bar **4** slides into the hole; turn anti-tilt nuts **6** to a distance of 1 mm from plate.
- Tighten the three bolts to fix the load cell **7**.

Upper plate

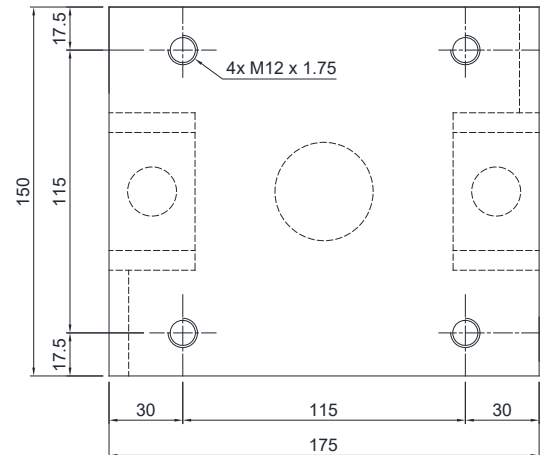

V10275 - Lower plate

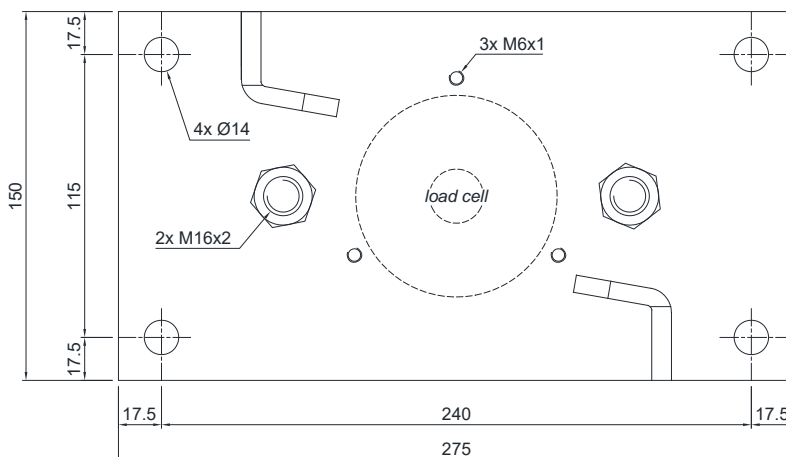

V10000 - Lower plate

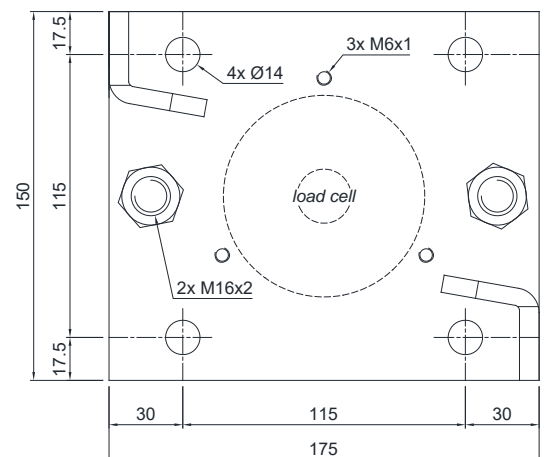

V10000: 6 kg
V10275: 7 kg

- 1 Load cell.
- 2 AISI 304 stainless steel upper and lower plates.
- 3 AISI 304 stainless steel laminas with horizontal constrainer function.
- 4 Threaded bar.
- 5 Nut to be used as jack.
- 6 Anti-tilt self-locking nut.
- 7 M6 bolts to fix the load cell.

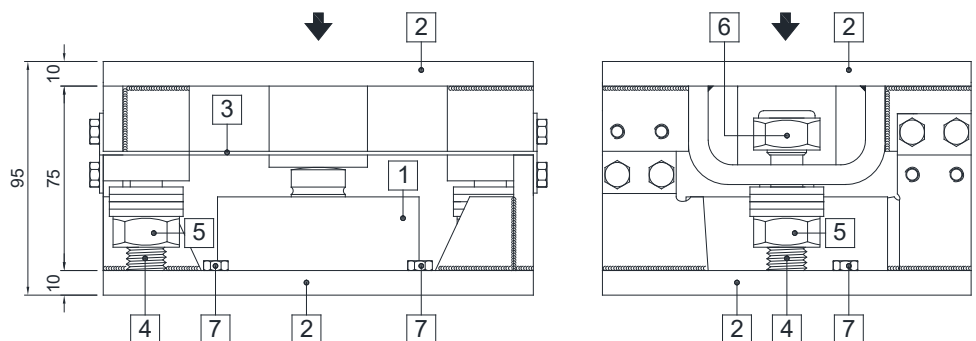

The Company reserves the right to make changes to the technical data, drawings and images without notice.