

## • XS2 Series Wireless Crane Scale

### Main Features

- 25mm large LED display
- Internal rechargeable battery with up to 50 hours of continuous use
- Tally roll printer – dot matrix
- Battery saving auto shut off
- WIRELESS operation

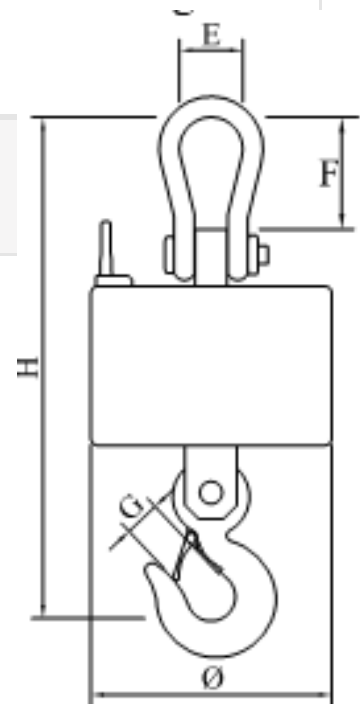

Specifications (t)	Dimension (mm)					Weight (kg)
	E	F	G	H	Ø	
5	75	85	45	690	270	31
10	90	106	45	760	270	41
30	180	230	100	1260	350	155

### Specifications

Model	XS2 series		
Capacity	5ton	10ton	30ton
Readability	2kg	5kg	10kg
Display	LED – red 25mm		
Tare	100% subtractive		
Overload	120% of rated capacity		
Printer	Built in mini dot matrix		
Will print	Date, Time, Weight, Accumulation, Totals		
Wireless Communication	Distance of 50~100m dependant on the environment		
Housing	Steel (load cell) – Aluminum Case (indicator + Printer)		
Temperature Limits	10°C ~ 40°C RH less than 90%		
Power Supply	AC Adaptor- 12V/500mA –Built in 7Ah Rechargeable Battery		



**CLOVER SCALES (PTY) LTD**

**JOHANNESBURG**  
 2 Kya Sand Rd. Kya Sand Randburg  
 PO Box 1474 Northriding 2162  
 Tel: (011) 462-3216/7/8/9  
 Fax: (011) 462-1936  
 e-mail: jhb@cloverscales.co.za

**CAPE TOWN**  
 Unit D2 Maitland Industrial Park  
 Voortrekker Road Maitland  
 PO Box 753 Maitland 7404  
 Tel: (021) 593-3108/9  
 Fax: (021) 593-9302  
 e-mail: cpt@cloverscales.co.za

**DURBAN**  
 Unit 1.8 Canberra Park  
 20 Canberra Road Umbilo Durban  
 PO Box 18658 Dalbridge 4014  
 Tel: (031) 304-1274/5/6  
 Fax: (031) 304-1225  
 e-mail: dbn@cloverscales.co.za

